

SECTION A-A

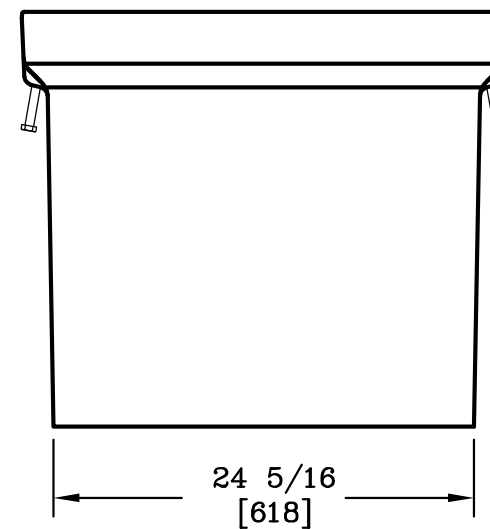
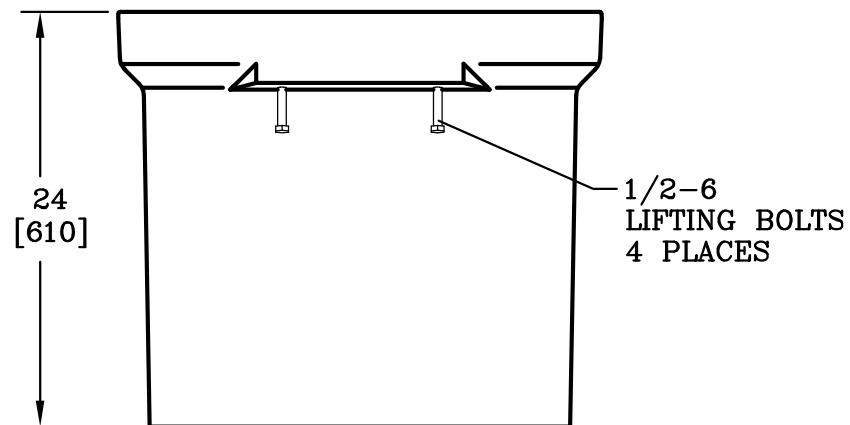

NOTE:

1. DIMENSIONS IN BRACKETS ARE IN MILLIMETERS UNLESS NOTED OTHERWISE.

DIMENSIONS ARE IN INCHES OR MILLIMETERS IN BRACKETS UNLESS OTHERWISE NOTED.				HUBBELL® 3621 INDUSTRIAL PARK DR LENOIR CITY, TN 37771 800-346-3062 www.quazite.com		LOC
DRN	BY	DATE	WEIGHT	DRAWING DESCRIPTION	QUAZITE® BOX	S
CHK			165# 75kg			REV
ENG			SCALE			C
APR			1"=1'			3/12
APR			SIZE			
PROJECT NUMBER			DRAWING NUMBER			
04647			PG2424BG24			
SHEET 1 OF 1						