

PARTS LIST					
ITEM	CATEGORY	PART NUMBER	DESCRIPTION	QTY	BASE UNIT
1	L	C080177	BOLT SS AUG 3/8-7 X 4.00 HEX	2	Each
2	L	C080210	WASHER SS 3/8 ID X 1.000 OD FL	2	Each

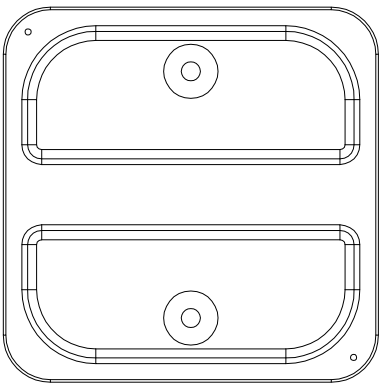

BOTTOM VIEW

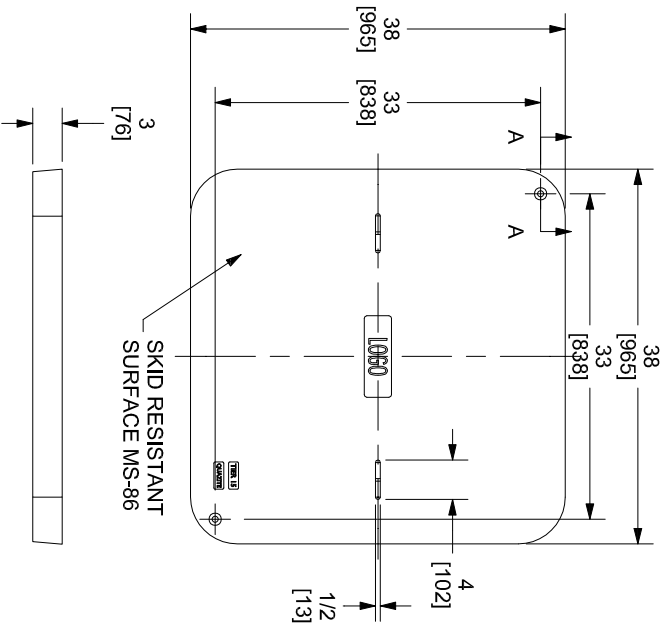
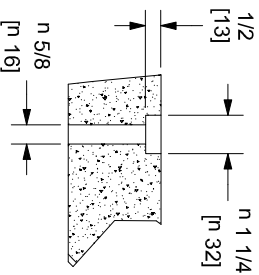

SECTION A-A
2 PLACES

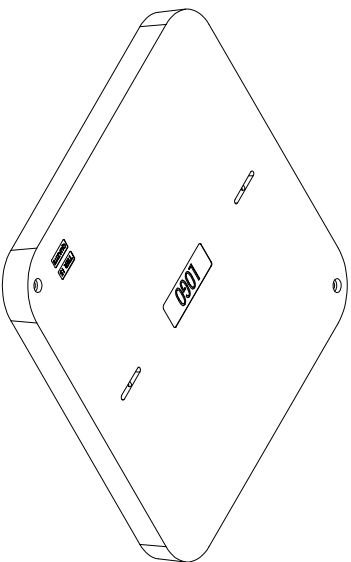

- NOTE:
1. RATED FOR A STATIC DESIGN LOAD OF 15,000 LBS. [666,720] OVER A 10 [254] X 10 [254] AREA AND MUST PASS A MINIMUM STATIC TEST LOAD OF 22,500 LBS. [100,080 N].



DIN		3/16/98	101kg	3621 INDUSTRIAL PARK DR LENOIR CITY, TN 37771 800-346-3062 www.quazite.com		LOC	LC
BR	DATE	222#	SCALE	DRAWING DESCRIPTION		REV	S
CHK	MR	3/16/98	NTS	QUAZITE® COVER		REV	E
ENG	MS	3/17/98	SIZE	DRAWING NUMBER		REV	4/18
APR	FMS	3/17/98	B	PG3636HA00			
ESK #	98181		SHEET 1 OF 1				