

1/2-6 SELF ALIGNING,
REPLACEABLE S.S. EZ-NUT
2 PLACES

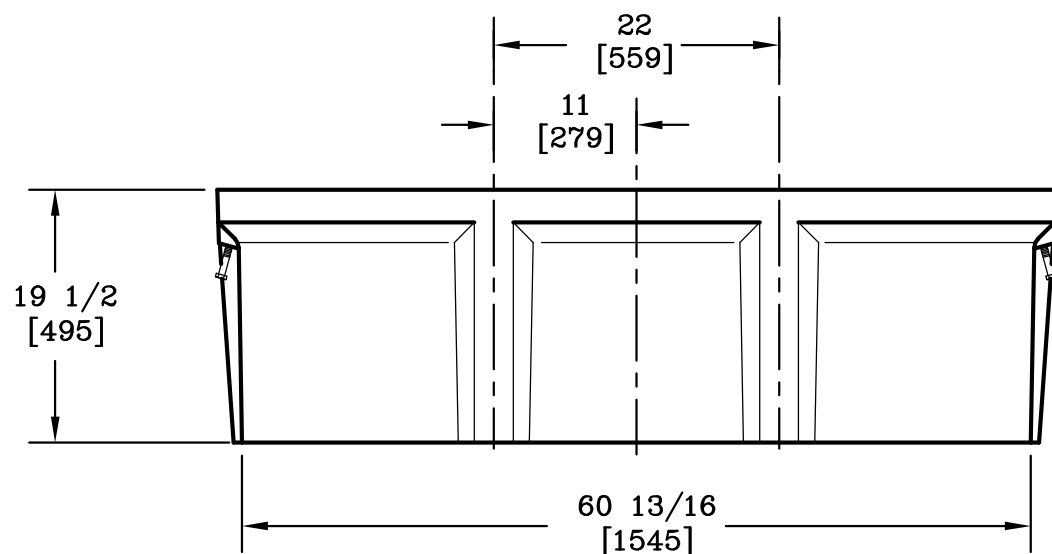

1/2-13 UNC
LIFTING BOLT
4 PLACES

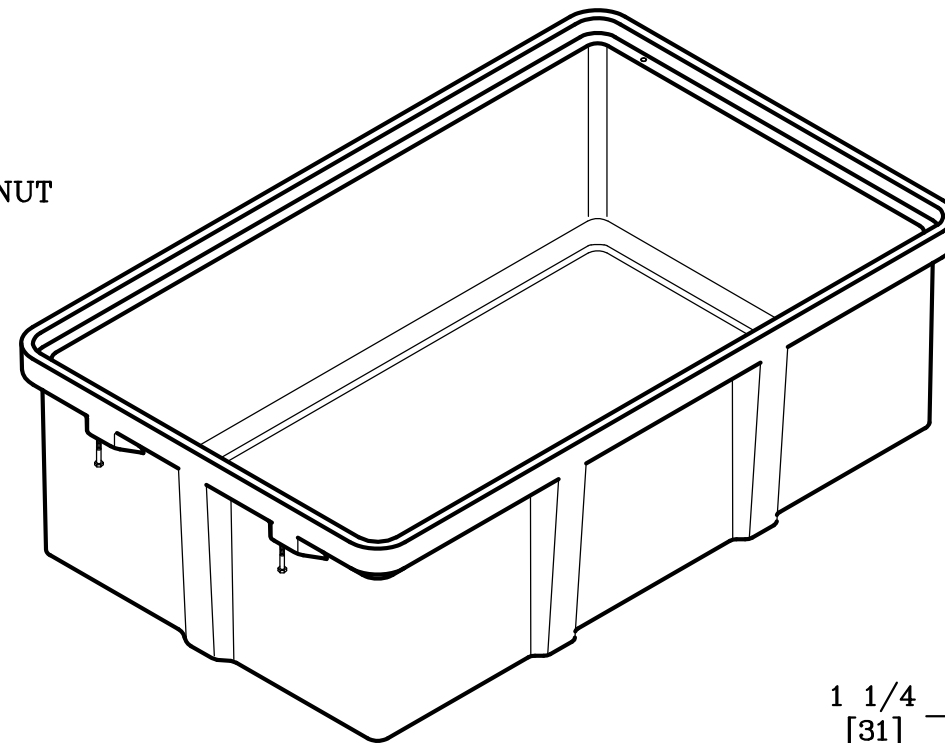
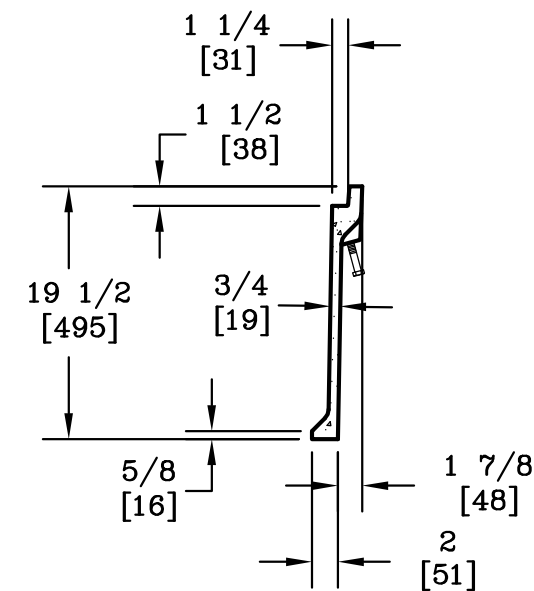
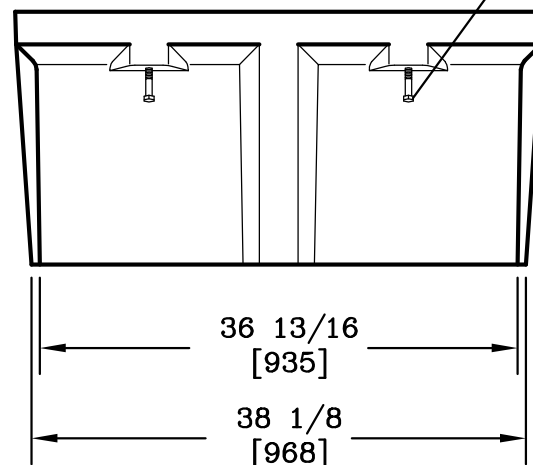

SECTION A-A

NOTE:

1. THIS BOX IS RATED FOR ANSI/SCTE 77 2007 TIER 22.

DIMENSIONS ARE IN INCHES OR MILLIMETERS IN BRACKETS UNLESS OTHERWISE NOTED.					
DRN	BY	DATE	WEIGHT	 3621 INDUSTRIAL PARK DR LENOIR CITY, TN 37771 800-346-3062 www.quazite.com	LOC
CHK	ENG	APR	APR		LC
380# 172kg	JJP	4/25/00	SCALE	DRAWING DESCRIPTION QUAZITE® 36 X 60 X 19 BOX STANDARD VERSION	REV
3/4"=1'	KPB	5/8/00	SIZE		C
B					3/12
PROJECT NUMBER			DRAWING NUMBER		
00249			PG3660BA19		
SHEET 1 OF 1					