

CUSTOMER APPROVAL  
 APPROVED BY: \_\_\_\_\_  
 DATE: \_\_\_\_\_

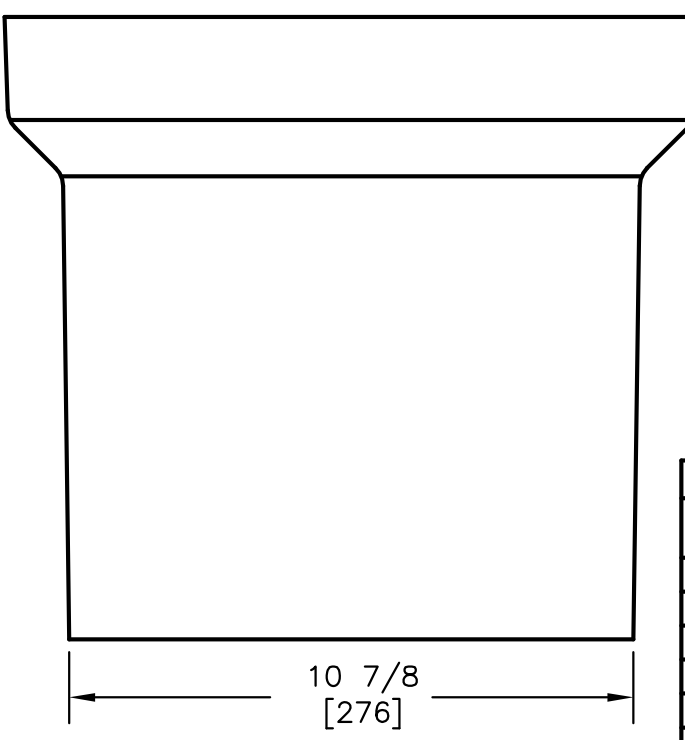
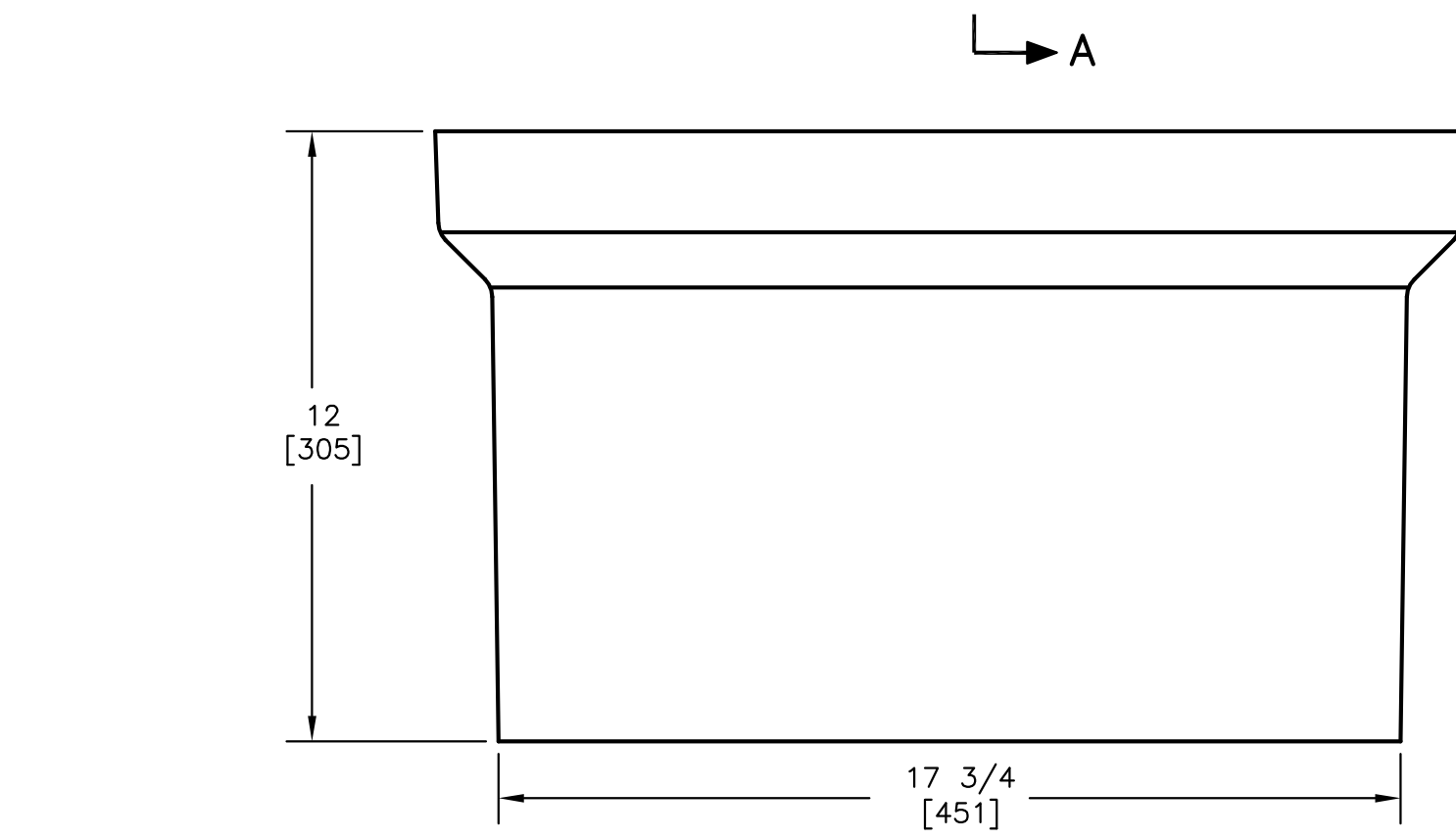
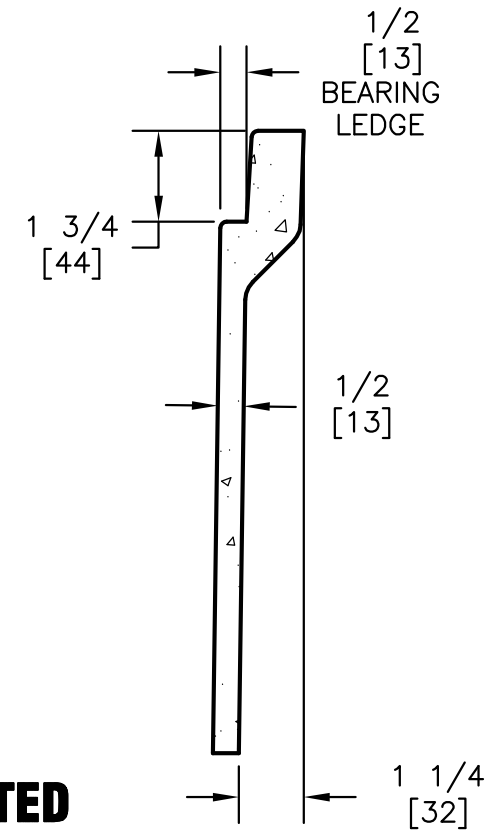
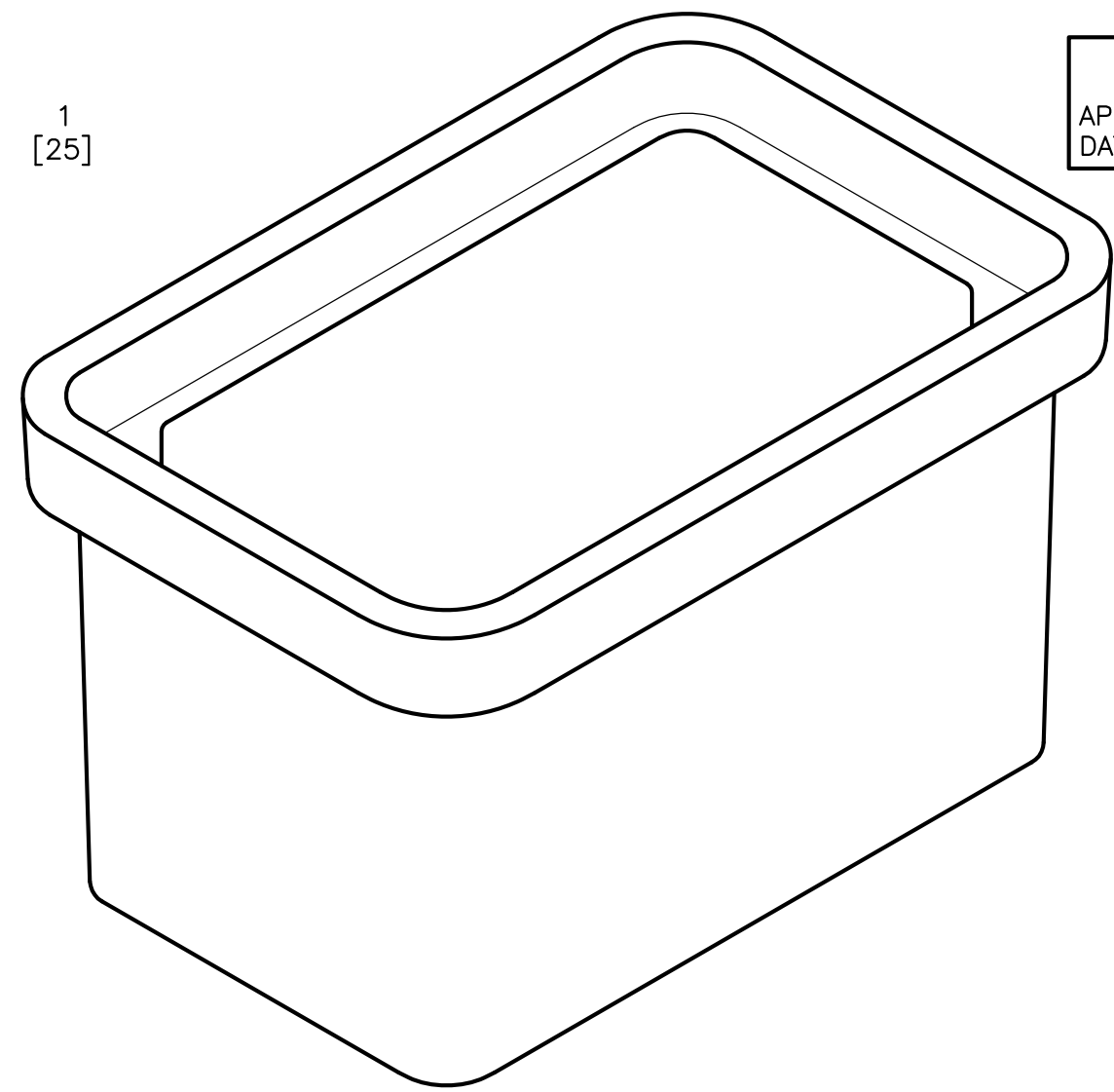
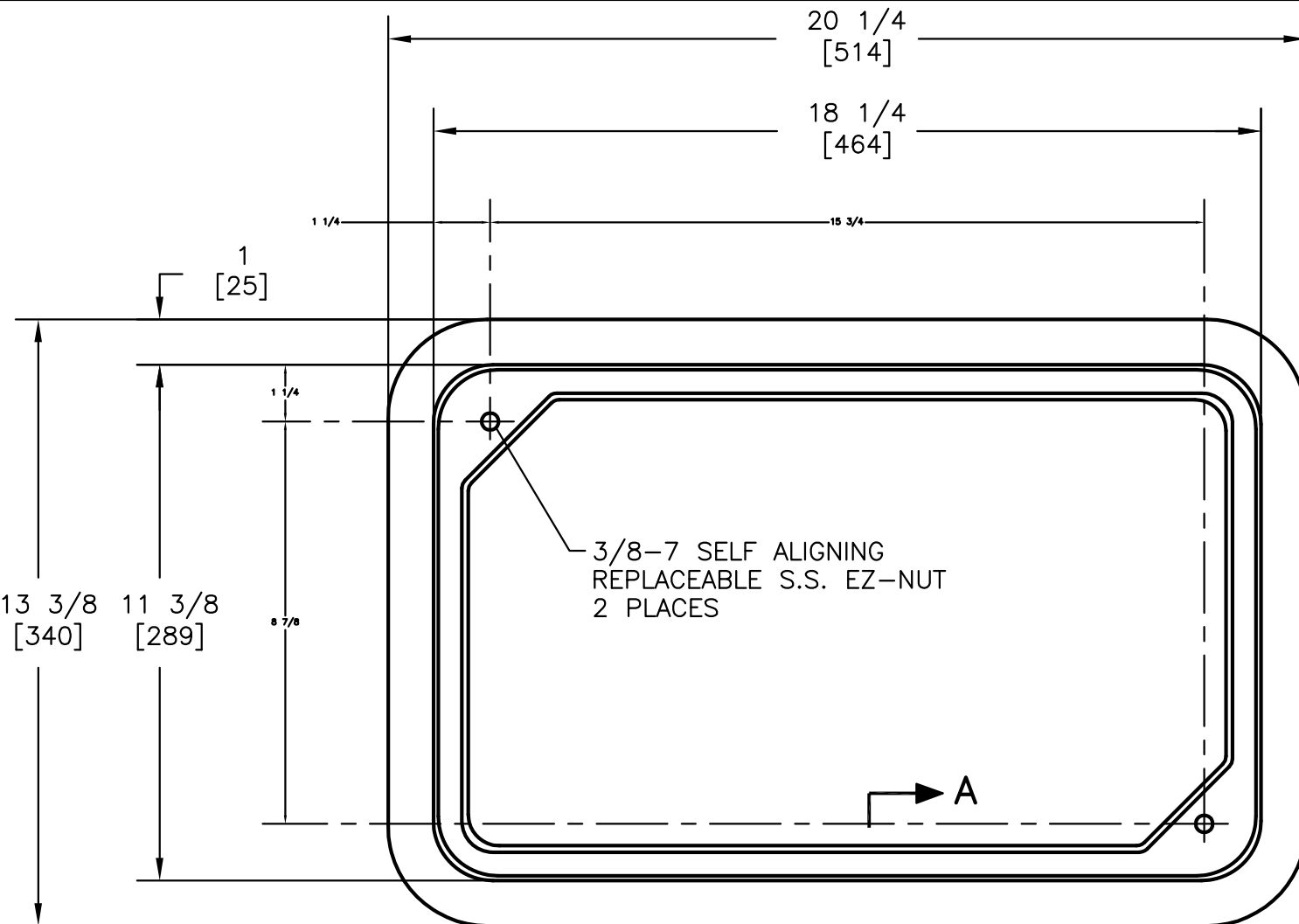

SECTION A-A

NOTE:  
 1. THIS BOX IS RATED FOR ANSI/SCTE 77 2010 TIER 22.

DIMENSIONS ARE IN INCHES OR MILLIMETERS IN BRACKETS UNLESS OTHERWISE NOTED.					
DRN	BY	DATE	WEIGHT	3621 INDUSTRIAL PARK DR LENOIR CITY, TN 37771 800-346-3062 www.quazite.com	LOC
CHK	MP	8/16/91	40# 18kg		S
ENG	MP	8/16/91	SCALE	DRAWING DESCRIPTION	REV
APR	MP	8/16/91	3"=1'		F
APR			SIZE		3/12
PROJECT NUMBER			DRAWING NUMBER		
91270			PG1118BA12		
SHEET 1 OF 1					